

# **Diemant ingerprint Door LockInstallation Manual**

V3.1





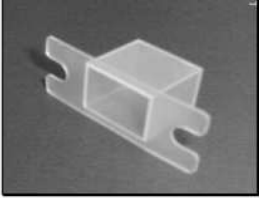







Table Contents

<b>1. Product and Accessories</b>	2
1.1 Parts	
List.....	2
1.2 Parts	
Identification.....	3
<b>Installation.....</b>	<b>5</b>
2.1 Preparation before Installation.....	5
2.2 Drill Holes.....	6
2.3 Adjust Latch’s Backset.....	6
2.4 Adjust Deadbolt’s Backset.....	7
<b>3 Install Latch, Deadbolt and Strikes .....</b>	<b>9</b>
3.1 Install Latch and Deadbolt .....	9
3.2 Install Strikes and Lining Boxes.....	10
<b>4 Install the Lock Units.....</b>	<b>11</b>
4.1 Adjust Torque Bar Length.....	11
4.2 Install Outside Unit.....	11
4.3 Install Inside Unit.....	12
4.4 Check and Adjust after Installation.....	13
<b>5 Problems or Feedback .....</b>	<b>13</b>

## **1. Product and Accessories**

### **1.1 Parts List**

After opening the package, please check the product and accessories. If any are missing or damaged, please contact your dealer for replacement.

		
Inside unit	Outside unit	Pinch screws
		
Deadbolt	Deadbolt strike	Deadbolt strike lining box
		
Latch	Latch strike	Latch strike lining box
		
Square axis for latch	Wood screw	Emergency keys
		
The Manual	Cutout template	

- 1 **Parts Identification**
- 2 **Installation**

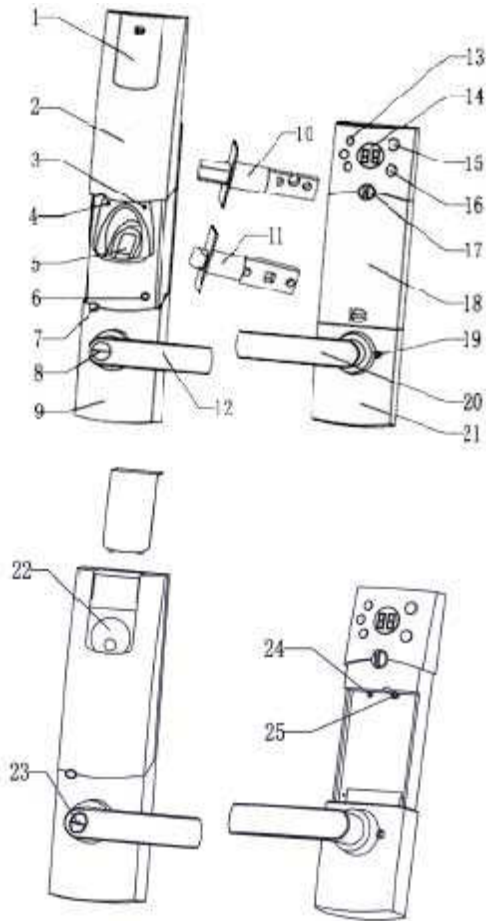

1. Decoration plate	14. LED display
2. Sliding dust cover	15. Inside unlocking button
3. Green LED indicator	16. Inside locking button
4. Red LED indicator	17. Battery compartment knob
5. Fingerprint scanning window	18. Battery compartment
6. Power on switch	19. Pinch screw holes

7. Outside locking button	20. Inside lever
8. Emergency keyhole cover	21. Inside unit body
9. Outside unit body	22. Deadbolt keyhole
10. Deadbolt	23. Latch emergency keyhole
11.Latch	24. Deadbolt emergency release hole
12.Outside lever	25. Pinch screw hole
13.Function keys	

## 2.1 Preparation before Installation

Your lock must correspond to your door being left-handed or right-handed. If not, you should ask your seller to exchange it. (Refer to Figure1)

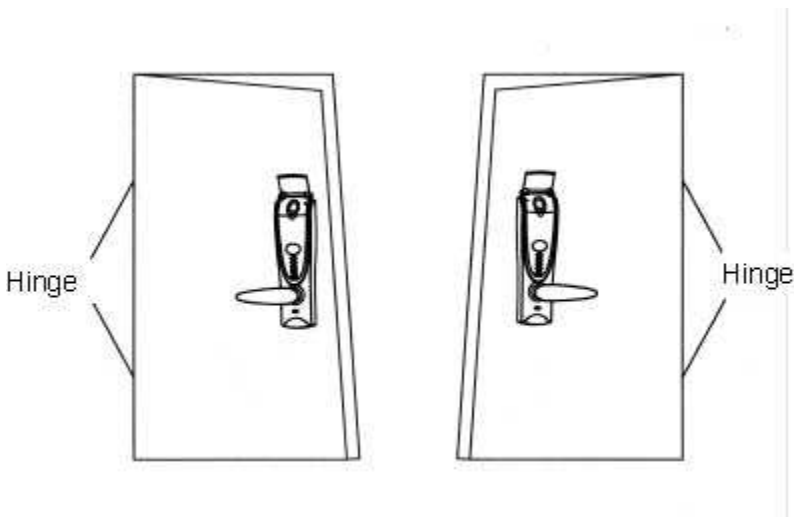

Left-Hand Door Right-Hand Door

**Fig 1: Viewing from the outside; definition of doors**

☒ **Tip: How to determine the door opening direction?**

*Standing outdoor and face the door: If the hinge is at the left side of the door, the door is a left-handed door - the left-handed lock should be used. If the hinge is at the right side of the door, the door is a right-handed door the right-handed lock should be used.*

The lock lever is designed to be interchangeable with the popular Schlage or Kwikset standard for 2 lock hole doors. If your door has only one hole or no holes in the door, follow the instructions below. (Note: Most hardware stores have 2-1/8" and 1" hole cutters that fit standard hand drills.)

## 2.2 Drill Holes

- (1) Paste the provided cutout template on the door as shown in the figure. Mark 1" holes at center of door edge and make 2" holes at the surface of the door (the offset is 2 3/8" or 2 3/4" from door edge to the center of the 2" hole).
- (2) Drill two 1" holes on door edge. And drill two 2" holes on the door surface.

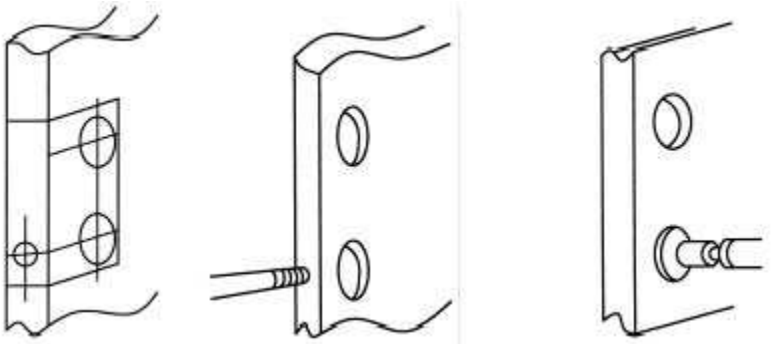

☒ **Hint:** *To avoid cracking the door surface, the 2" holes should be drilled from both sides.*

(3) There are adjustable backsets for the latch and deadbolt. Set them to either 2 3/8" or 2 3/4" as appropriate for your door.

## 2.3 Adjust Latch's Backset

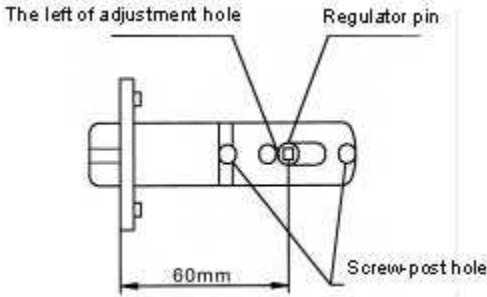

**The backset is at the 2 3/8" position, when the product is shipped from the factory.**

The clip of regulator pin Regulator pin Pull

Pull regulator pin to the right edge.

The right edge of adjust hole Screw-post hole

The backset has been adjusted to 2 3/4" position.

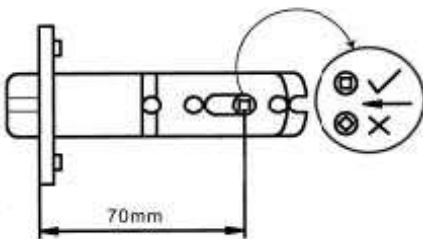

**Make sure the regulator pin is at the correct angle as shown.**

## 2.4 Adjust the Deadbolt's Backset

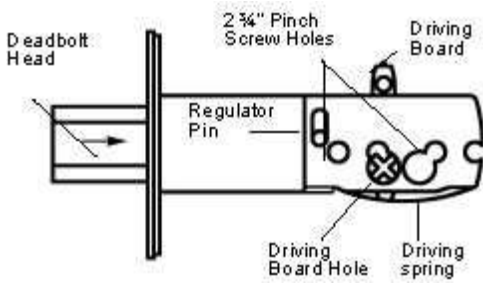

Insert a flat screwdriver into driving board hole, turn driving board to let the deadbolt head draw in.



	<p>Pull regulator pin up, firmly hold driving board and driving spring and pull right until the 2 3/4" screw hole coincides with driving board hole.</p>
<p>Regulator Pin</p>	<p>Figure shows the backset is in 2 3/4" position.</p>
<p>Stretcher Board</p>	<p>If you would like to return to the 2 3/8" backset, make sure deadbolt is drawn in. Pull regulator pin up, push back convex stretcher to its original position.</p>

### 3 Install Latch, Deadbolt and Strikes

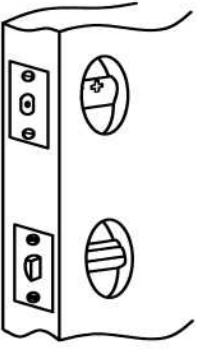
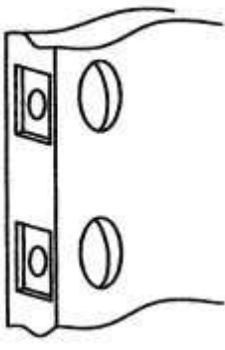
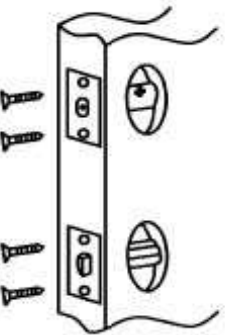
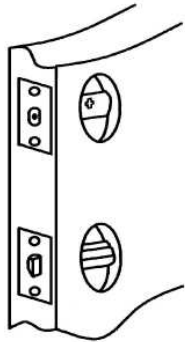
#### 3.1 Install Latch and Deadbolt

	
<p>Insert the lock bolt into the hole, mark the frame lines of foil board. The frame lines should be parallel with the door edge.</p>	<p>Dig a support notch 1/8" in depth. The notch edge lines should be parallel with the door edge.</p>
	
<p>Insert latch and deadbolt, and tighten the screws (the slanted plane of latch should face the door closing direction, and the UP mark of the deadbolt should point down).</p>	<p>After the screws are tightened, the foil board should be exactly in the door center and parallel with door edge.</p>

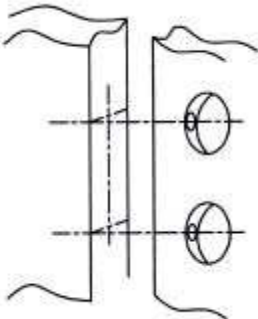
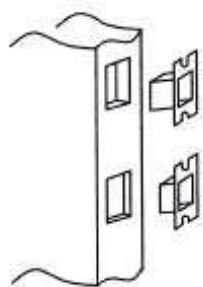
### 3.2 Install Strikes and Lining Boxes

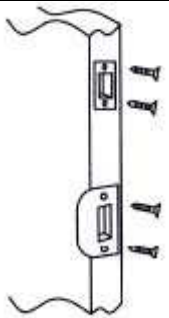
	
<p>Close the door; use pencil to mark strike hole in the doorjamb from face hole.</p>	<p>Cut out a square cavity to accept the strike box at the marked location in the doorjamb.</p>
	
<p>Draw strike plate line and screw holes Cut 1/16" notches for the strike plates.</p>	<p>Install strikes, tighten the screws.</p>

## 4 Install the Lock Units

(Note: The **Diemant** fits standard door thicknesses of 1 1/2" to 2 1/8". It is possible to fit doors down to 1" and up to 2 1/4" in thickness door by ordering special length of torque bars and square axes from manufactory.

### 4.1 Adjust Torque Bar Length

The length of torque bar is longer than normal when shipped from the factory. You need to cut off enough to make the tip of torque bar below surface of inner

door surface by about 1/8" (see Figure 2).

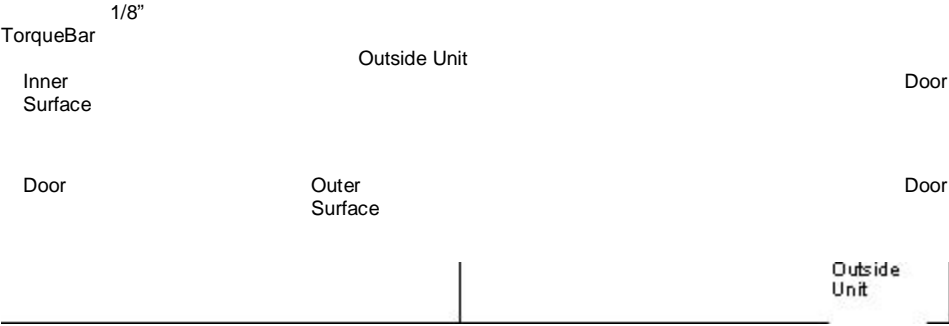
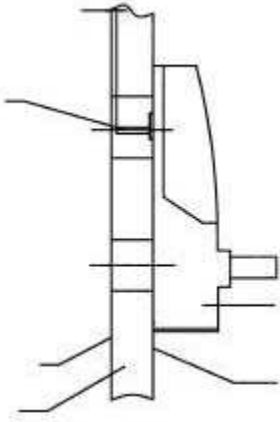
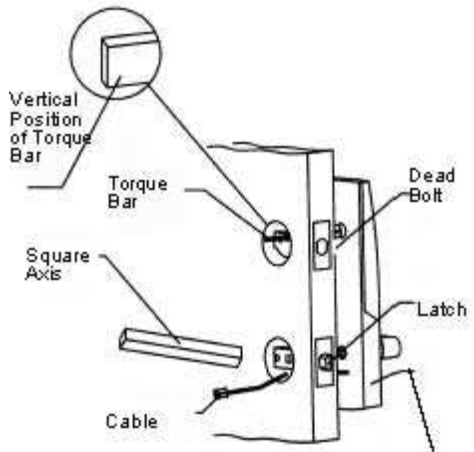

Fig 2 Fig 3



## 4.2 Install Outside Unit

- (1) Pass the connecting cable through the door face along the lower hole.
  - (2) Make sure the torque bar is in vertical direction and the deadbolt is
- 11

DL210 Installation Manual V3.1

stretched out. Hold Outside unit close on the door surface, then insert the torque bar into the crossed slot of deadbolt.

(3) Pass the square axle through the square hole of regulator pin of the latch and the outside lever connecting with the Outside unit.

## 4.3 Install Inside Unit

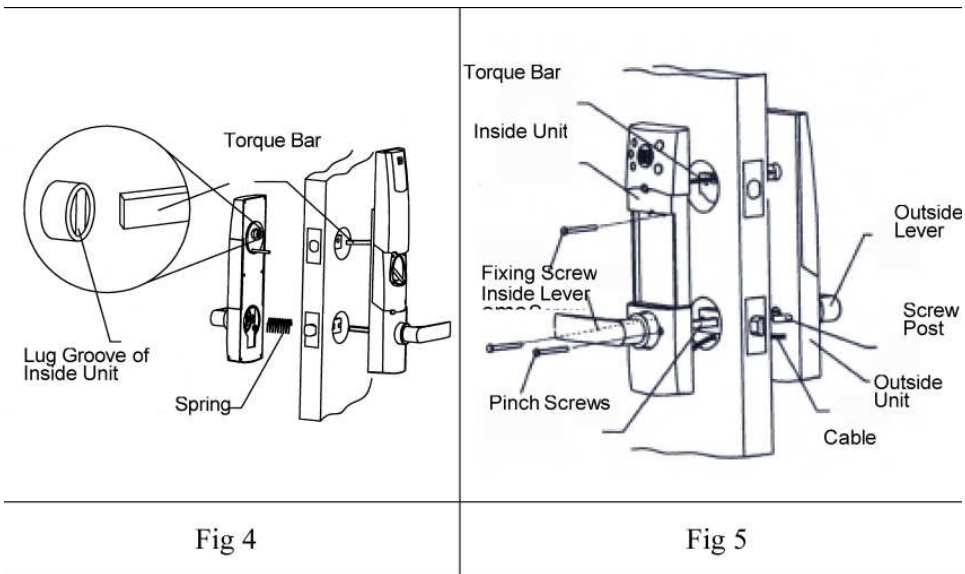

Fig 4

- (1) Remove knob and battery compartment.
- (2) Put the spring (which is packed with pinch screws in accessories bag) into the square hole on Inside unit. (see Figure 4)
- (3) Adjust the lug groove on Inside unit to vertical position with screwdriver (see Figure 4).
- (4) Insert the connector on the cable into J7 on the Inside unit.
- (5) Align torque bar and square axis and insert into the corresponding grooves of Inside unit. Push Inside unit to inner door surface.

**⊠Warning:** *The surplus cable should not be wound around the mechanism.*

- (6) Fasten three pinch screws (see figure 4).

#### 4.4 Check and Adjust after Installation

Check the mechanical assembly as follows:

- (1) Leave door open, install the battery compartment with 6 AA batteries.
- (2) Turn inside lever, latch should move freely in and out. Turn outside lever, latch should not move.
- (3) Press Inside LOCK button, deadbolt should pop out; press Inside UNLOCK button, deadbolt should retract.

□ (4) Press Outside LOCK button, deadbolt should pop out.

⌘ **Tip:** If the deadbolt does not moves smoothly, loosen pinch screws a little and adjust the lock body position until the deadbolt moves smoothly.

## **5 Problems or Feedback**

In case of problems, contact your dealer or [www.bezklicu.cz](http://www.bezklicu.cz)

Email: [info@bezklicu.cz](mailto:info@bezklicu.cz)

Phone: 00420-720-171000